

In line with continued product development Innovative Technology Ltd reserves the right to change specifications without prior notice.

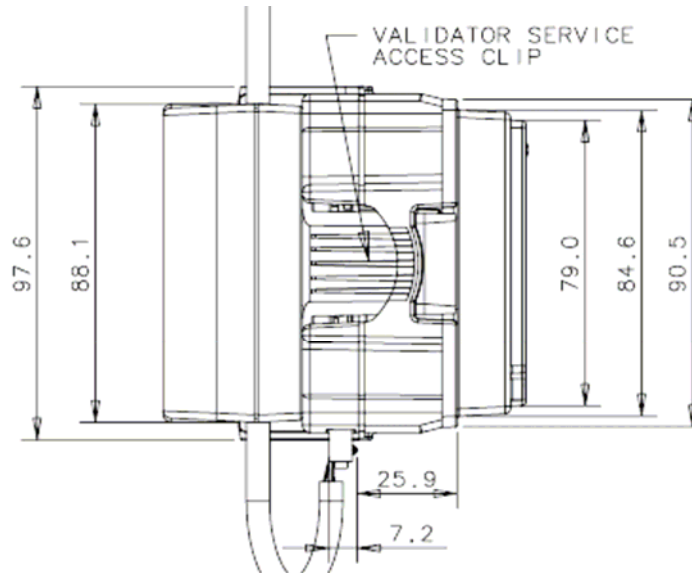
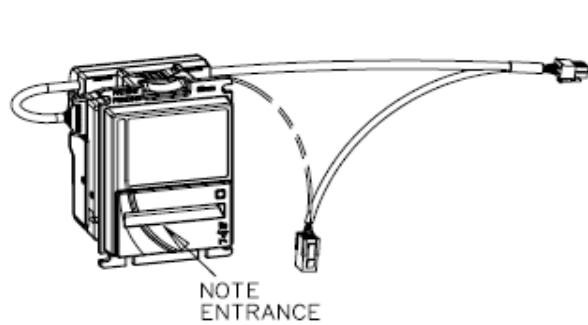

**ACCEPTS NOTES:**

1. 66 mm x 160 mm LONG

2. 72 mm x 160 mm LONG

**ENVIRONMENTAL OPERATING RANGE:**

+3 °C to +50 °C at 5% to 95% RH  
(NON - CONDENSING)

UNLADEN WEIGHT: 0.4 KG

**SECTION 'Z-Z'**

