

# MC-WB DIMENSIONS

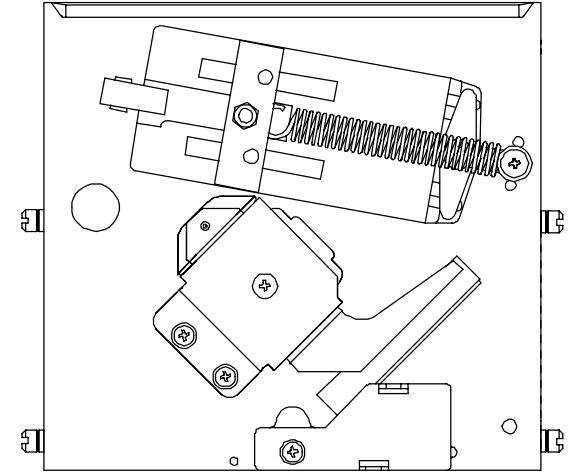

- NOTE: 1. BREAK OFF SPACER TAB FOR COINS LESS THAN 1.875 DIA.  
2. REMOVE SPACER FOR COINS BETWEEN 1.250 - 1.600.

NOTE:  
IT IS IMPERATIVE THAT THE HOST MACHINE DELIVER COINS INTO THE MECHANISM BY REFERENCING THE CENTERLINE OF THE MOUNTING STUDES TO THE INSIDE SURFACE OF THE METAL MAINPLATE. THIS .25"/6.3mm REFERENCE DIMENSION HAS NOT CHANGED SINCE MECHANICAL MECHANISM USAGE. THIS ALIGNMENT DIMENSION IS IMPORTANT BECAUSE THE REFERENCE IS THE SAME REGARDLESS OF THE DROP SLOT GAP THAT IS AVAILABLE IN DIFFERENT COIN MECHANISM MODELS.

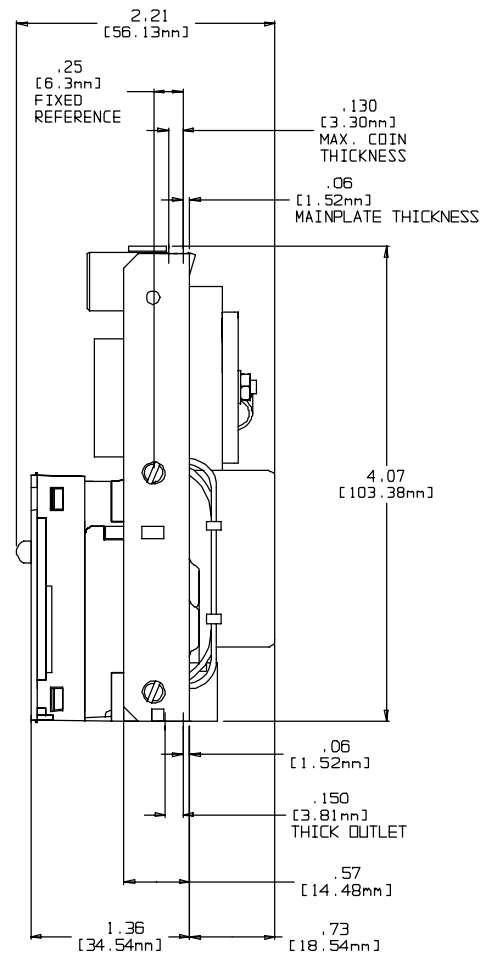
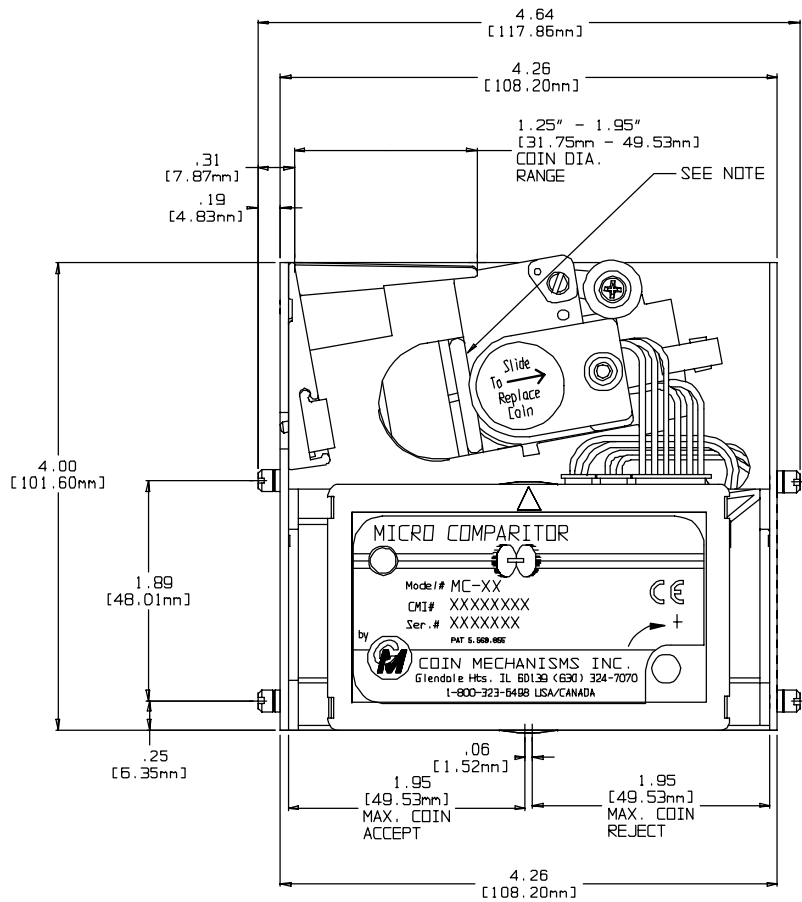

## COIN MECHANISMS INC.

P.O. Box 5128, Glendale Heights, IL 60139-5128 P/N ENG00082 -5/02  
630/924-7070\*1-800/323-6498\*FAX 630/924-7088\*E-MAIL-coinmech@coinmech.com  
VISIT OUR WEB SITE AT [www.coinmech.com](http://www.coinmech.com)